



Nível de dificuldade



Quantidade de pessoas

### Recursos necessários:

Chave philips ou parafusadeira, chave de fenda, trena, alicate, lápis e esquadro.

### Orientações gerais:

Para a funcionalidade do produto é necessário a utilização de dobradiça com 110°.

A capacidade de carga de cada bandeja é de 10Kg. Todas as medidas deste produto são em milímetros.

## Itens fornecidos:

A. Bandeja metálica

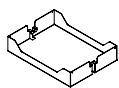

B. Montante coluna



C. Montante extensor coluna

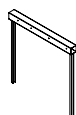

D. Chapa U 70x50x55mm



E. Corrediça telescópica 350mm

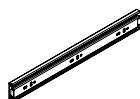

F. Paraf. CH FC M4x8mm



G. Porca MA-4 CH 7



H. Paraf. AAC. PN FC 4,2x16mm



I. Paraf. Tellep SX Int. M6x20mm OT



J. Chave Tellep M-3



K. Terminal INT. 40x40mm



L. Paraf. Aço G10 MQ CIL. SXT. INT. NC3/16"x24mmx5/8" OT



M. Paraf. PN FC M3,5x14mm



N. Braço móvel articulação



O. Braço fixo articulação



P. MC-13 Distanciador 8,5mmx3/16"x1/4" INC.



Q. Paraf. MQ FS 3/16"x1" REDONDA



R. Arruela 3/16"x1/2"



S. Paraf. MQ FS 3/16"x5/8"



T. Porca SEXT. Aut-trava 3/16"



U. Paraf. PN FC 3,5x16mm



V. Paraf. M. FIX PN FC 3,9x16mm Broca



X. Extensor de articulação



1. Desmonte a corrediça baixando o engate como mostra o detalhe abaixo:

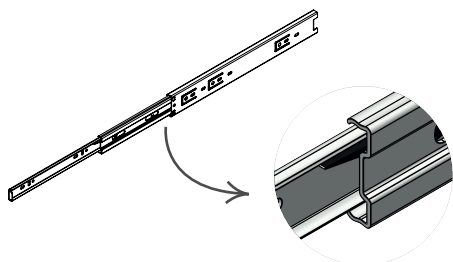

2. Fixe a chapa externa da corrediça (E) na chapa U (D) utilizando as ferragens (F) e (G).

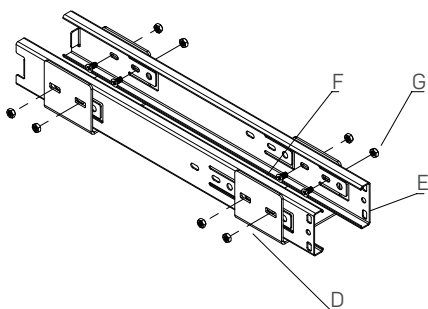

3. Fixe a parte interna da corrediça no montante (B) utilizando a ferragem (H). Faça isso na parte inferior e superior do montante, conforme imagens abaixo:

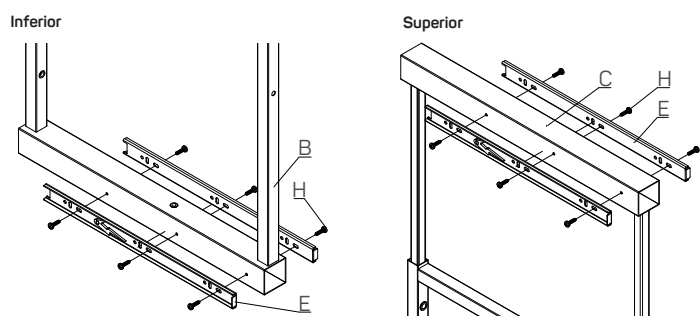

4. Para fazer o ajuste de altura do montante extensor (C) coloque o parafuso (I) no montante conforme indicado na imagem. Use a chave (J) e faça o aperto final depois de prender no móvel.

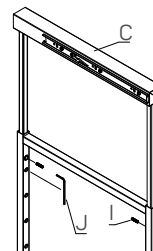

5. Faça a montagem dos terminais (K) conforme imagem abaixo:

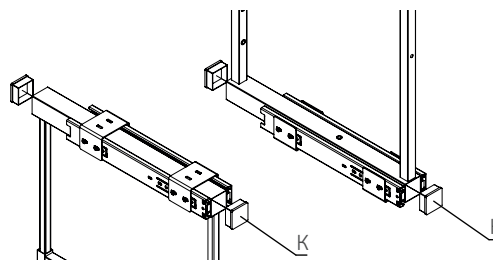

6. Monte os carrinhos dentro do móvel conforme as marcações sinalizadas na imagem abaixo:

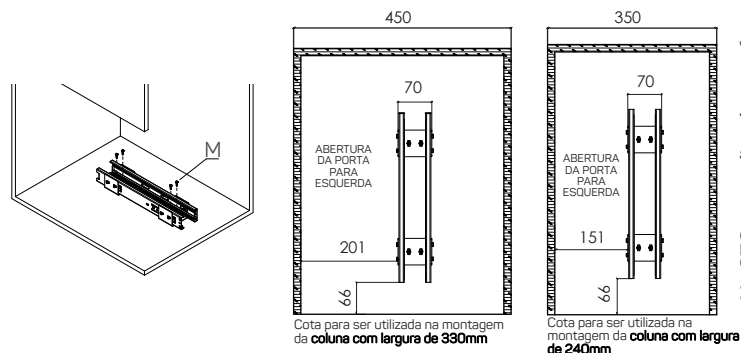

7. Monte a chapa articulação (N) no montante utilizando as ferragens (Q) e (P).

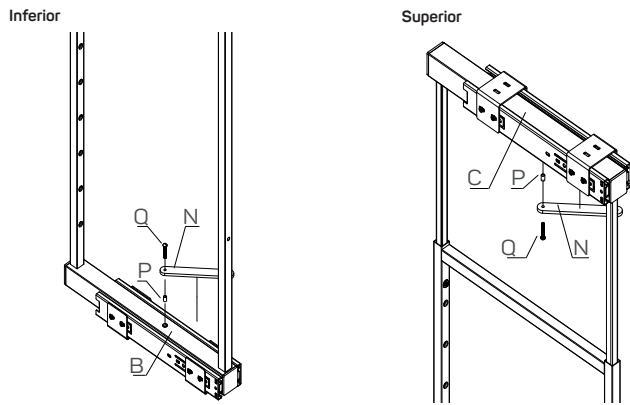

8. Realize a montagem das gavetas (A) no montante (B) fazendo uso do parafuso (L). A regulagem de altura entre as bandejas é de acordo com a necessidade do cliente.

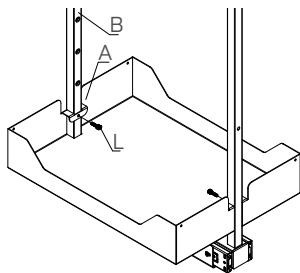

9. Encaixe o montante com as bandejas no carrinho que está preso no móvel.

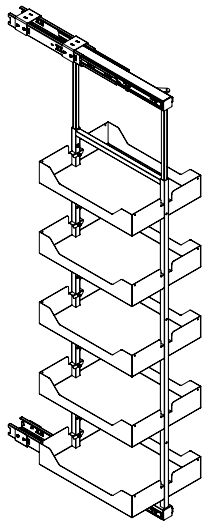

10. Monte o braço articulação (O) na chapa (N) fazendo uso das ferragens (S), (R) e (T).

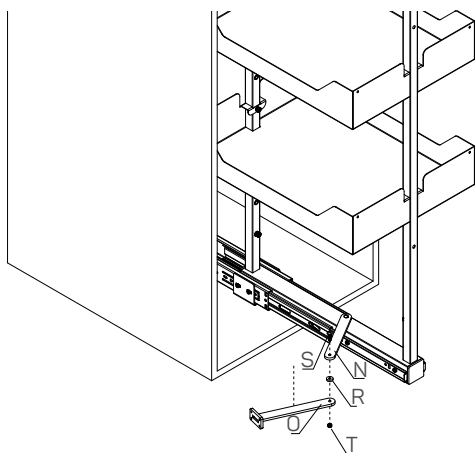

11. Fixe o braço da articulação (O) na porta do móvel usando a ferragem (U). Posicione na porta conforme as cotas apresentadas no desenho. **Obs:** a medida de Z é o valor da metade da espessura do MDF.

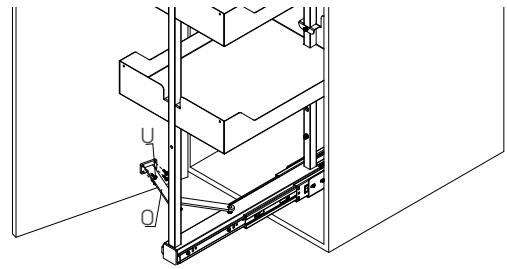

Cotas

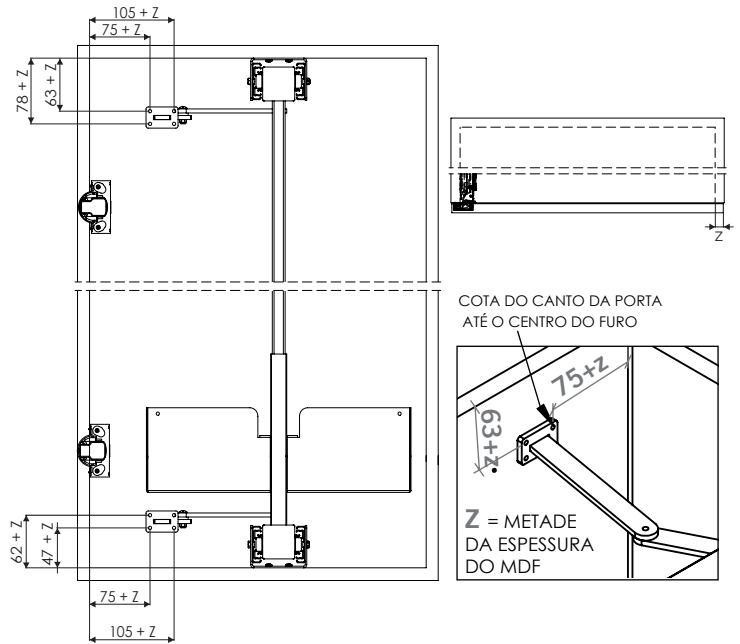

#### Orientação adicional para montagem das colunas altas de largura 240mm

12. Faça a montagem da chapa extensora (X) conforme indicação das ferragens na imagem abaixo. Após realizar a fixação na porta conforme as cotas indicadas.

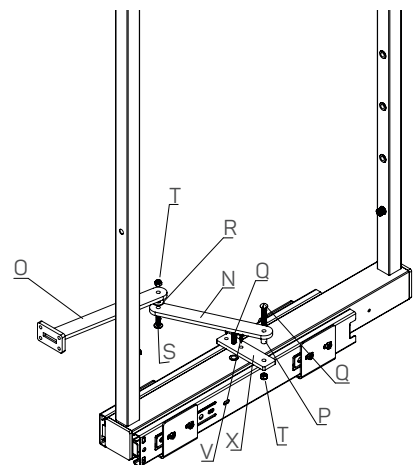

Cotas

